

ESS502I/V/IIC Flush Diaphragm Ceramic Pressure Sensor Module (Electronic on PCB | Electronic on Ceramic)



- Range: 0~5bar~70bar~200bar
- Diaphragm Material: Ceramic Al₂O₃ 96%
- Integrated accuracy: 0.5%
- Output: 0.5-4.5Vdc | 4-20mA | I2C
- Flush Diaphragm Ceramic
- Electronic on PCB | Ceramic

Description

Based on ESS502 flush diaphragm ceramic sensing cell, ESS502 I/V/IIC pressure sensors module is integrated electronic on pcb or on ceramic, which amplify the output from mv to analogy signal such as 0.5-4.5Vdc or 4-20mA and I2C.

Because of the Al₂O₃ ceramic excellent chemical resistance (aggressive gases, most of solvents and acids, etc.), no additional protection is normally required.

Key Features & Benefits

- Pressure range 0~5bar...0bar
- Excellent resistance to corrosion and abrasion
- Absolute measurement available
- Thermally compensated
- Extended customization
- Flush Diaphragm

Application

- Cooling equipment & A/C system
- Automotive and vehicle
- Industrial process control
- HVAC system
- Refrigeration equipment
- Air conditioning unit

Technical Characteristics [for sensor module]

Parameter	Unit	Description			
Sensor type	-	Absolute (A), Gauge (R) or Sealed gauge (S)			
Technology	-	Piezoresistive			
Diaphragm material	-	Ceramic Al ₂ O ₃ 96% (standard), 99.6% or sapphire (Sapphire is underway)			
Weight	g	≤ 8 (ceramic cell only) ; ≤ 30 (module)			
Response time	ms	≤ 1 (@90%/FS)			
Output signal		0-5V	I2C	0.5-4.5V	4-20mA
Supply voltage	VDC	2...36	2.7-5.5	3.0-5.5	11-36
Current cons.	mA	≤ 3 @ 10V	2.5(TYP)	2.5(TYP)	-
Impedance	Ω	11k ± 30%	>10k	>10k	≤50 (U-11)

Offset	mv/v	- 0.2 ± 0.1 (Other nominal values available on request)											
Operating temperature	°C	-40...+85°C (-40 °F...+185 °F)											
Storage temperature	°C	-40...+125°C (-40 °F...+257 °F)											
Nominal pressure FSO	bar	0.5*	1*	2*	5	10	20	50	100	200	400*	600	800
	psi	7	14	29	73	145	290	725	1450	2900	5800	8700	11600
Overload pressure	bar	1	2	4	10	15	35	100	150	350	500	750	1000
	psi	14	29	58	145	217	507	1450	2175	5075	7250	10875	14500
Burst pressure	bar	2	3	6	15	25	65	120	200	500	650	950	1250
	psi	29	43	87	217	362	942	1740	2900	7250	9425	13775	18125
Vacuum capability	bar	-0.1	-0.5	-1	-1	-1	-1	-1	-1	-1	-1	-1	-1
	psi	-1.4	-7	-14	-14	-14	-14	-14	-14	-14	-14	-14	-14
Type	-	R	A/R/S	A/R/S	A/R/S	A/R/S	A/R/S	A/R/S	S	S	S	S	S
Total thickness	mm				6.30	6.30	6.35	6.55	6.78	6.95			
	in	0.242	0.2432	0.245	0.248	0.250	0.258	0.263	0.263	0.278	0.288	0.297	0.317
Sensitivity	mv/v	1.4-	2.0-3.6	2.3-3.5	2.3-4.0	3.1-5.5	2.4-4.0	4.0-6.0	3.0-4.8	2.5-3.9	3.1-4.8	3.1-4.8	2.0-3.5
Accuracy	%/fs	0.4/0.	0.3/0.9	0.3/0.6	0.2/0.4	0.2/0.5	0.2/0.5	0.2/0.5	0.2/0.5	0.4/0.9	0.5/1.0	0.5/1.0	0.5/1.0
Thermal offset shift(typ./max.)	%/fs/k	± 0.005 / ± 0.040				25 °C...85 °C				(77 °F...185 °F)			
Thermal span shift	%/fs/k	≤ ± 0.010		0 °C...70 °C		(32 °F...158 °F)		≤ ± 0.012		-25 °C...0 °C / 70 °C...85 °C		(-13 °F...32 °F / 158 °F...185 °F)	
		≤ ± 0.014		-40 °C...-25 °C / 85 °C...135 °C		(-40 °F...-13 °F / 185 °F...275 °F)							
Reliability tests	-	1000 hours @85 °C (185 °F) & 85 %RH						500 thermal shocks -40°C...+150 °C (-40 °F... +302 °F)					
		1000 hours burn-in @150 °C (302 °F)						10 million 0 bar to Pnom pressure cycles					

Tests performed at 25°C in Eastsensor housings, unless otherwise specified. Different housings may affect performances.

1. Psi values for reference only.

2. The sensitivity of each production batch is constant, within the indicated range and with minimal dispersion.

3. Accuracy = √(NonLinearity² + Hysteresis² + NonRepeatability²), terminal based.

4. All technical characteristics will remain within indicated ranges performing the above-mentioned reliability tests.

5. Please consult manufacturer when pressure range with "*" *

Drawing

<p>[FLUSH DIAPHRAGM] ESS502-I/V/IIC Ceramic Piezo-resistive Pressure Sensor Module Electronic on PCB</p>	<p>Output: 4-20mA Power Supply: 11-36V Output: 0.5-4.5V Power Supply: 5V Output: I2C Power Supply: 2.7-5.5V</p>									
<p>Available Range: 0-5 bar 0-10 bar 0-16 bar 0-20 bar 0-25 bar 0-35 bar 0-50 bar 0-70 bar 0-100 bar 0-200 bar</p>										
<p>Side View (without supporter) Schematics</p>	<p>Range: 0bar~200bar,</p>									
	<table border="1"> <tr> <td>1</td> <td>2</td> <td>3</td> </tr> <tr> <td>Power supply</td> <td>Output Voltage</td> <td>Power supply</td> </tr> <tr> <td>"+"</td> <td></td> <td>"-"</td> </tr> </table>	1	2	3	Power supply	Output Voltage	Power supply	"+"		"-"
1	2	3								
Power supply	Output Voltage	Power supply								
"+"		"-"								

Top View (without supporter) | Schematics

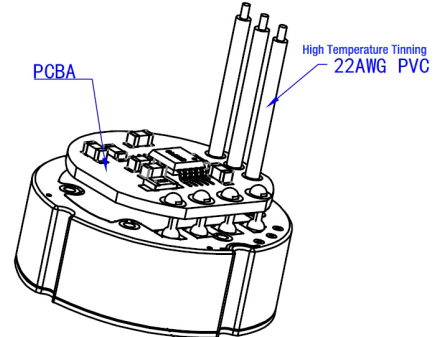
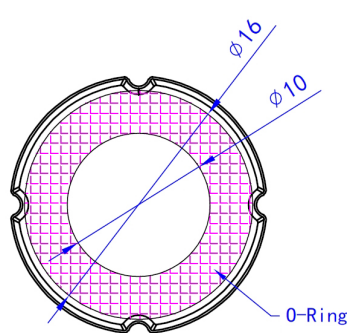
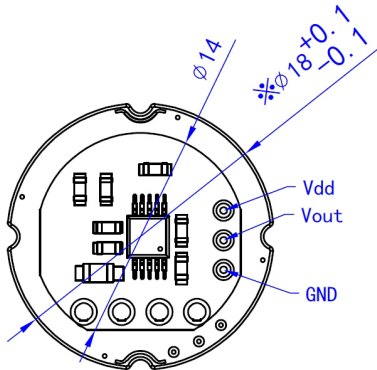

【 FLUSH DIAPHRAGM 】 ESS502-I/V/IIC Ceramic Piezo-resistive Pressure Sensor Module | Electronic on Ceramic

Available Range: 0-5 bar | 0-10 bar | 0-16 bar | 0-20 bar | 0-25 bar | 0-35 bar | 0-50 bar | 0-70 bar | 0-100 bar

Output: 4-20mA Power Supply: 11-36V
 Output: 0.5-4.5V Power Supply: 5V
 Output: I2C Power Supply: 2.7-5.5V
 Output: SENT/SPI (Customized)
 Range: 0bar~70bar,

Top View (without supporter) | Schematics

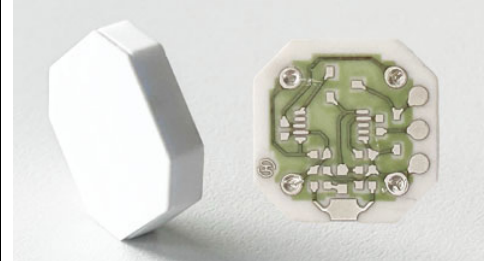
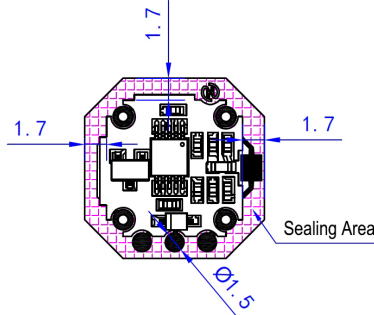
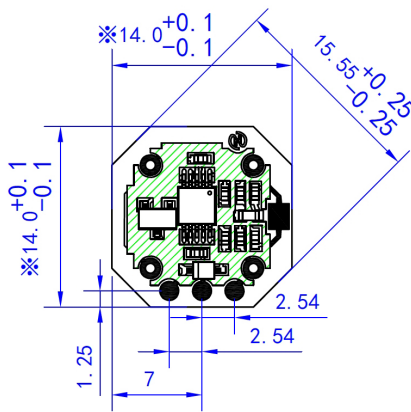

Output Signal	0.5-4.5V
Vs	Voltage Supply
Out	Voltage Output
GND	Ground

Side View (without supporter) | Schematics

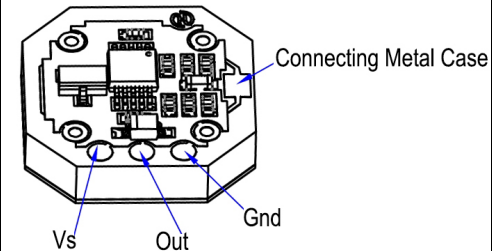
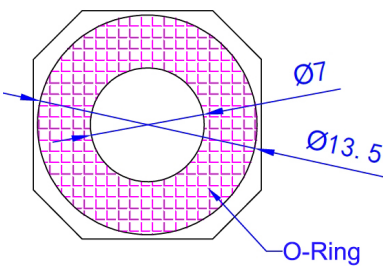
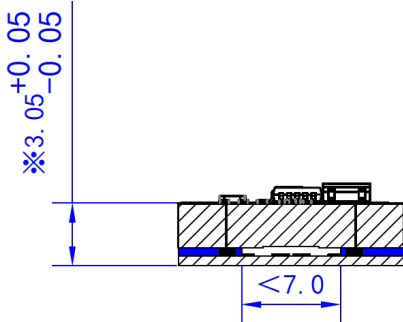

- 1. Storage Conditions:** Store at 10~35°C with ≤70% RH. Avoid places that are too hot, exposed to direct sunlight, dusty, or have corrosive gases. The metal pins can easily oxidize in the air, so it's recommended to use the product within 10 days after unpacking. Under proper storage conditions, the soldering validity is 12 months. If stored for more than 12 months, the ceramic core needs to be rechecked for solderability and can only be used if it passes inspection.
- 2. Product Installation Pressure:** During crimping installation, the crimping pressure should not exceed 20KN, and the direct pressure on the core should not exceed 5KN. Excessive force may damage the core structure or cause abnormal output signals. The ceramic core should not come into direct contact with hard objects like a metal casing to avoid significant internal stress and unstable output.
- 3. Sealing Recommendations:** When using sealing rings, ensure that the sealing ring is centered with the elastic diaphragm and without uneven force. The inner diameter of the sealing ring should be >10.0mm and the outer diameter <16.0mm after compression deformation.

Ordering Procedure

ESS5	Ceramic Piezoresistive Pressure Sensor							
	Code	Model						
	01	Pressure Sensor Cell, Monolithic 18*6.35mm						
	01 Thin	Pressure Sensor Cell, Monolithic 18*3.35mm						
	01-I	Pressure Sensor Module, Monolithic (with pcb) 4-20mA; Electronics on PCB						
	01-V	Pressure Sensor Module, Monolithic (with pcb) 0.5-4.5V; Electronics on PCB						
	01-IIC	Pressure Sensor Module, Monolithic (with pcb) I2C Output; Electronics on PCB						
	02 (18)	Pressure Sensor Cell, Flush diaphragm 18*6.35mm						
	02 (18)Thin	Pressure Sensor Cell, Flush diaphragm 18*3.35mm						
	02 (12)	Pressure Sensor Cell, Flush diaphragm 12*12*3mm						
	02 (14)	Pressure Sensor Cell, Flush diaphragm 14*14*3mm						
	02 (21)	Pressure Sensor Cell, Flush diaphragm 21*4.35mm						
	02-I	Pressure Sensor Module, Flush diaphragm (with pcb) 4-20mA; Electronics on PCB						
	02-IOC	Pressure Sensor Module, Flush diaphragm (with pcb) 4-20mA; Electronics on Ceramic						
	02-V	Pressure Sensor Module, Flush diaphragm (with pcb) 0.5-4.5V; Electronics on PCB						
	02-VOC	Pressure Sensor Module, Flush diaphragm (with pcb) 0.5-4.5V; Electronics on Ceramic						
	02-IIC	Pressure Sensor Module, Flush diaphragm (with pcb) I2C Output; Electronics on PCB						
	02-IICOC	Pressure Sensor Module, Flush diaphragm (with pcb) I2C Output; Electronics on Ceramic						
	03	Pressure Sensor Cell (with temperature sensor mounted), Monolithic 18*6.35mm						
	03 Thin	Pressure Sensor Cell (with temperature sensor mounted), Monolithic 18*3.35mm						
		Code	Span	Code	Span			
		R01	0...0.5 bar [0...7psi]	R07	0...50 bar [0...720psi]			
		R02	0...1 bar [0...14psi]	R08	0...100 bar [0...1450psi]			
		R03	0...2 bar [0...29psi]	R09	0...200 bar [0...2900psi]			
		R04	0...5 bar [0...72psi]	R10	0...400 bar [0...5800psi]			
		R05	0...10 bar [0...145psi]	R11	0...600 bar [0...8700psi]			
		R06	0...20 bar [0...290psi]	R12	0...800 bar [0...11600psi]			
		Code	Pressure Type					
		R	Gauge					
		A	Absolute					
		S	Sealed Gauge					
		Code						
		M	Monolithic					
		F	Flush Diaphragm					
		Code	Sensitivity adjustment					
		0	Without					
		9	On request					
		Code	Output					
		0	0.5-4.5Vdc					
		9	4-20mA					
		10	IIC					
		Code	Termination type					
		02	Pre-tinned pads					
		03	Silicone single wires 80 mm-100 mm					
		07	Customization Type					
		Code	Accuracy					
		1	0.5%					
		2	1.0%					
		9	Others on request					
ESS5	02-I	R06	R	F	0	9	03	1

Note: ① Extremely attention must be paid to sensor installation process to avoid any miss conduction that affect the sensor performance, ② please protect the diaphragm and the compensated board carefully to prevent any damage. ③ Please contact us if your requested working temperature lower than -20 °C