

ESS502 Ceramic Piezo-Resistive Pressure Sensor Cell FLUSH DIAPHRAGM THICK-FILM | Al₂O₃ 96%

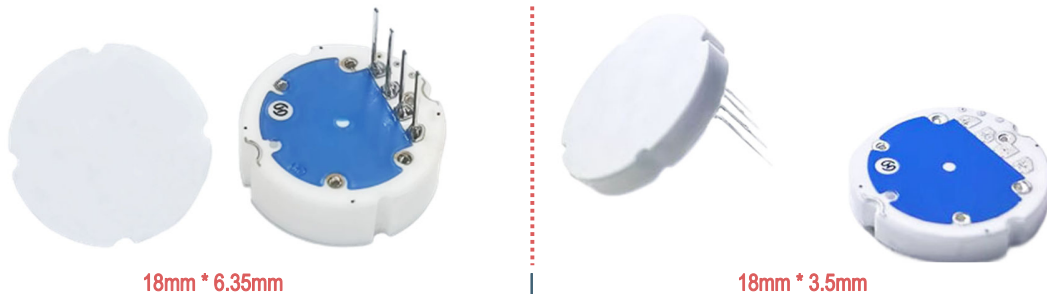

- **Range:** 0~100bar/200bar
- **Size:** 18mm*6.35mm; 18mm*3.5mm
- **Diaphragm Material:** Ceramic Al₂O₃ 96%
- **Power Supply:** 2-30V
- **Long Term Stability:** 0.3%/FS
- **Temperature Compensation:** -10...70°C
- **Working Temperature:** -40...+135 °C

Description

ESS502 **Flush Diaphragm Pressure Sensor Cell** are made with a **Ceramic Base Plate and Diaphragm** and work following the piezoresistive principle. The Wheatstone bridge is **Screen Printed** on one side of the flush ceramic diaphragm which is, in turn, glued to the sensor's body. The bridge faces the inside where a cavity is made and the diaphragm's opposite side can therefore be exposed directly to the medium to be measured.

The Wheatstone bridge is screen printed directly on one side of the ceramic diaphragm by means of **Thick Film Technology**. Because of the **Al₂O₃ Ceramic** excellent chemical resistance (aggressive gases, most of solvents and acids, etc.), no additional protection is normally required. Thanks to the reinforced outer area (monolithic structure), the sensor can be mounted directly in a plastic or metallic case by using O-ring.

ESS502 **Flush Diaphragm Pressure Sensor Cell** are available with two kind size: **18*6.35mm** and **18*3.5mm (thin type)**, both are thermally compensated by laser-adjustable PTC resistors and the use of ceramic ensures a high linearity across the entire range of measurement, reducing effects of hysteresis to a minimum.

Key Features & Benefits

- **Pressure range 0-5bar-100bar/200bar**
- **Excellent resistance to corrosion and abrasion**
- **Absolute measurement available**
- **Thermally compensated**
- **Extended customization**
- **Extended choice of measuring ranges**

Application

- **Cooling equipment & A/C system**
- **Automotive and vehicle**
- **Industrial process control**
- **HVAC system**
- **Refrigeration equipment**
- **Air conditioning unit**

Technical Characteristics

Parameter	Unit	Description
Sensor type	-	Flush diaphragm, absolute (A), gauge (R) or sealed gauge (S)
Technology	-	Piezoresistive (Ceramic Thick Film)
Diaphragm material	-	Ceramic Al ₂ O ₃ 96% (standard), 99.6% or sapphire (on request)
Weight	g	≤ 8 (ceramic cell only)
Response time	ms	≤ 1
Supply voltage	VDC	2...30

Offset	mv/v	- 0.1 ± 0.1 (Other nominal values available on request)												
Current cons.	mA	≤ 1.3 @ 10V												
Operating temperature	°C	-40...+135 (-40 °F...+275 °F)												
Storage temperature	°C	-40...+150 (-40 °F...+302 °F)												
Impedance	kΩ	11 ± 30%												
Nominal pressure FSO	bar	0.5*	1*	2*	5	10	20	50	100	200 *	400 *	600 *	800 *	
	psi	7	14	29	73	145	290	725	1450	2900	5800	8700	11600	
Overload pressure	bar	1	2	4	10	15	35	100	150	350	500	750	1000	
	psi	14	29	58	145	217	507	1450	2175	5075	7250	10875	14500	
Burst pressure	bar	2	3	6	15	25	65	120	200	500	650	950	1250	
	psi	29	43	87	217	362	942	1740	2900	7250	9425	13775	18125	
Vacuum capability	bar	-0.1	-0.5	-0.5	-1	-1	-1	-1	-1	-1	-1	-1	-1	
	psi	-1.4	-7	-7	-14	-14	-14	-14	-14	-14	-14	-14	-14	
Type	-	R	A/R/S	A/R/S	A/R/S	A/R/S	A/R/S	A/R/S	S	S	S	S	S	
Total thickness	mm/in					6.30 ± 0.05	6.35 ± 0.05	6.45 ± 0.05	6.65 ± 0.05	6.78 ± 0.05	6.95 ± 0.05			
	mm/in					3.30 ± 0.05	3.30 ± 0.05	3.35 ± 0.05	3.45 ± 0.05	3.78 ± 0.05	for thin type			
Sensitivity 2	mv/v					2.3-4.0	3.1-5.5	2.4-4.0	4.0-6.0	3.0-4.8	2.5-3.9			
Accuracy 3 Thermal offset shift	%/fs					0.2/0.4	0.2/0.5	0.2/0.5	0.2/0.5	0.2/0.5	0.4/0.9			
Thermal offset shift (typ./max.)	%/fs/k	± 0.005 / ± 0.040				25 °C...85 °C				(77 °F...185 °F)				
Thermal span shift	%/fs/k	≤ ± 0.010				0 °C...70 °C				(32 °F...158 °F)				
		≤ ± 0.012				-25 °C...0 °C / 70 °C...85 °C				(-13 °F...32 °F / 158 °F...185 °F)				
		≤ ± 0.014				-40 °C...-25 °C / 85 °C...135 °C				(-40 °F...-13 °F / 185 °F...275 °F)				
Reliability tests 4	-	1000 hours @85 °C (185 °F) & 85 %RH 1000 hours burn-in @150 °C (302 °F)						500 thermal shocks -40°C...+150 °C (-40 °F... +302 °F) 10 million 0 bar to Pnom pressure cycles						

Tests performed at 25°C in Eastsensor housings, unless otherwise specified. Different housings may affect performances.

1. Psi values for reference only.
2. The sensitivity of each production batch is constant, within the indicated range and with minimal dispersion.
3. Accuracy = $\sqrt{\text{NonLinearity}^2 + \text{Hysteresis}^2 + \text{NonRepeatability}^2}$, terminal based.
4. All technical characteristics will remain within indicated ranges performing the above-mentioned reliability tests.
5. Please consult manufacturer when pressure range with "*"*

Drawing

ESS502 Ceramic Piezo-resistive Pressure Sensor Range: 0bar~200bar | [FLUSH DIAPHRAGM]

Top View: Pitch 2.54mm (0.100 inches)	Side View	Bottom View
---------------------------------------	-----------	-------------

Top View: Pitch 2.54mm (0.100 inches). Dimensions include $\phi 14.5$, $\phi 18$ (+0.1, -0.1), and 5.5. Labels: Vs, S-, Gnd, S+.

Side View: Dimensions include $2.54^{+0.2}_{-0.2}$, $4 \times 0.5^{+0.1}_{-0.1}$, $10.00^{+0.5}_{-0.5}$, and ≤ 9.5 .

Bottom View: Dimensions include H, $4 \times 0.3^{+0.1}_{-0.1}$, $\phi 16$, and $\phi 10$. Label: O-Ring.

Vs	Voltage Supply
Gnd	Ground
S+	Signal positive
S-	Signal negative

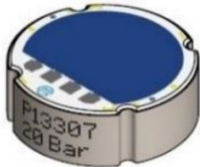
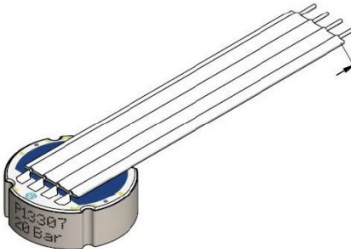
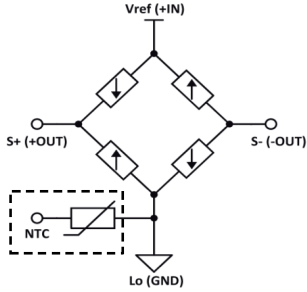
<p>Type A: Pre-tinned soldering pads</p> 	<p>Pitch: 2.54 ± 0.05 Op. Temp: -40°C...+135°C Type A; -40°C...+105°C Type B Cable length: 80.8 ± 2</p>	<p>Type B: Polyester/Silicone cable</p> 	<p>Schematics</p> 
---	---	---	--

ESS502 [Thin Type] Ceramic Piezo-resistive Pressure Sensor Range: 0bar~100bar | [FLUSH DIAPHRAGM]

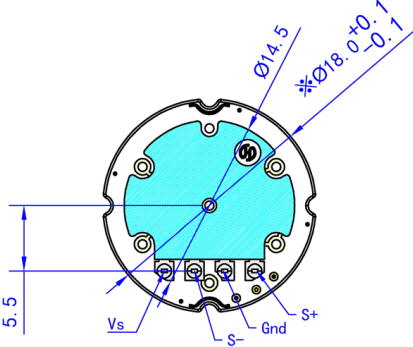
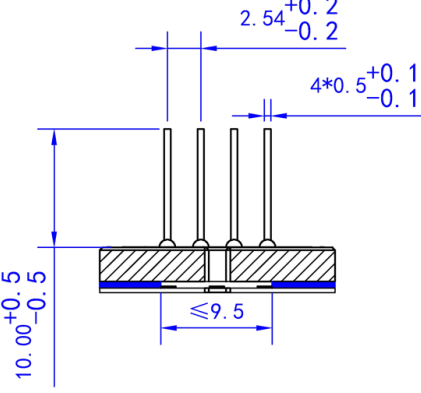
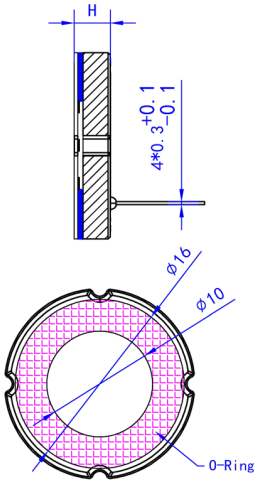
<p>Top View: Pitch 2.54mm (0.100 inches)</p>  <table border="1" data-bbox="140 1169 571 1267"> <tr> <td>Vs</td> <td>Voltage Supply</td> </tr> <tr> <td>Gnd</td> <td>Ground</td> </tr> <tr> <td>S+</td> <td>Signal positive</td> </tr> <tr> <td>S-</td> <td>Signal negative</td> </tr> </table>	Vs	Voltage Supply	Gnd	Ground	S+	Signal positive	S-	Signal negative	<p>Side View</p> 	<p>Bottom View</p> 
Vs	Voltage Supply									
Gnd	Ground									
S+	Signal positive									
S-	Signal negative									

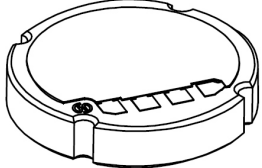
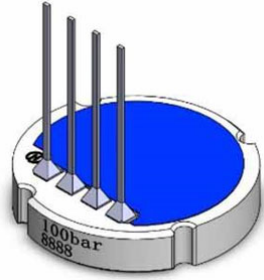
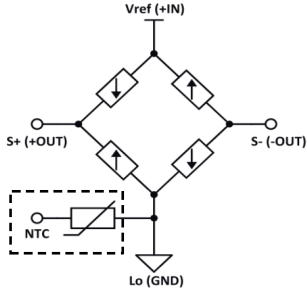
<p>Type A: Pre-tinned soldering pads</p> 	<p>Pitch: 2.54 ± 0.05 Op. Temp: -40°C...+135°C Type A; -40°C...+105°C Type B Pin section: 0.51 x 0.25 Pin length: L = 9.0 ± 0.5</p>	<p>Type B: 4 Pitch: 2.54 ± 0.05;</p> 	<p>Schematics</p> 
---	---	--	--

- Storage Conditions:** Store at 10~35°C with ≤70% RH. Avoid places that are too hot, exposed to direct sunlight, dusty, or have corrosive gases. The metal pins can easily oxidize in the air, so it's recommended to use the product within 10 days after unpacking. Under proper storage conditions, the soldering validity is 12 months. If stored for more than 12 months, the ceramic core needs to be rechecked for solderability and can only be used if it passes inspection.
- Product Installation Pressure:** During crimping installation, the crimping pressure should not exceed 20KN, and the direct pressure on the core should not exceed 5KN. Excessive force may damage the core structure or cause abnormal output signals. The ceramic core should not come into direct contact with hard objects like a metal casing to avoid significant internal stress and unstable output.
- Sealing Recommendations:** When using sealing rings, ensure that the sealing ring is centered with the elastic diaphragm and without uneven force. The inner diameter of the sealing ring should be >10.0mm and the outer diameter <16.0mm after compression deformation.
- Solder Pads:** The pressure core PIN is constructed of nickel-tin copper. The welding hole for the PIN measures 0.8mm, with a pad width exceeding 0.5mm. The soldering temperature must not exceed 370 °C, with each soldering session limited to under 3 seconds and a maximum of 3 sessions.

Ordering Procedure

ESS5	Ceramic Piezoresistive Pressure Sensor						
	Code	Model					
	01	Pressure Sensor Cell, Monolithic 18*6.35mm					
	01 Thin	Pressure Sensor Cell, Monolithic 18*3.35mm					
	01-I	Pressure Sensor Module, Monolithic (with pcb) 4-20mA; Electronics on PCB					
	01-V	Pressure Sensor Module, Monolithic (with pcb) 0.5-4.5V; Electronics on PCB					
	01-IIC	Pressure Sensor Module, Monolithic (with pcb) I2C Output; Electronics on PCB					
	02	Pressure Sensor Cell, Flush diaphragm 18*6.35mm					
	02 Thin	Pressure Sensor Cell, Flush diaphragm 18*3.35mm					
	02-I	Pressure Sensor Module, Flush diaphragm (with pcb) 4-20mA; Electronics on PCB					
	02-IOC	Pressure Sensor Module, Flush diaphragm (with pcb) 4-20mA; Electronics on Ceramic					
	02-V	Pressure Sensor Module, Flush diaphragm (with pcb) 0.5-4.5V; Electronics on PCB					
	02-VOC	Pressure Sensor Module, Flush diaphragm (with pcb) 0.5-4.5V; Electronics on Ceramic					
	02-IIC	Pressure Sensor Module, Flush diaphragm (with pcb) I2C Output; Electronics on PCB					
	02-IICOC	Pressure Sensor Module, Flush diaphragm (with pcb) I2C Output; Electronics on Ceramic					
	03	Pressure Sensor Cell (with temperature sensor mounted), Monolithic 18*6.35mm					
	03 Thin	Pressure Sensor Cell (with temperature sensor mounted), Monolithic 18*3.35mm					
		Code	Span	Code	Span		
		R01	0...0.5 bar [0...7psi]	R07	0...50 bar [0...720psi]		
		R02	0...1 bar [0...14psi]	R08	0...100 bar [0...1450psi]		
		R03	0...2 bar [0...29psi]	R09	0...200 bar [0...2900psi]		
		R04	0...5 bar [0...72psi]	R10	0...400 bar [0...5800psi]		
		R05	0...10 bar [0...145psi]	R11	0...600 bar [0...8700psi]		
		R06	0...20 bar [0...290psi]	R12	0...800 bar [0...11600psi]		
		Code	Pressure Type				
		R	Gauge				
		A	Absolute				
		S	Sealed Gauge				
		Code	Sensitivity adjustment				
		0	Without				
		9	On request				
		Code	Thermal offset				
		0	≤ ± 0.06 % FS/K (not thermally compensated)				
		1	≤ ± 0.04 % FS/K				
		2	≤ ± 0.02 % FS/K				
		Code	Termination type				
		02	4 pins, Pre-tinned pads, pitch 2.54 mm				
		03	4 pins, Silicone single wires 80 mm, pitch 2.54 mm				
		Code	Additional coating				
		1	Without				
		2	Parylene coating				
ESS5	02	R08	R	0	2	03	1

Note: ❶ Extremely attention must be paid to sensor installation process to avoid any miss conduction that affect the sensor performance, ❷ please protect the diaphragm and the compensated board carefully to prevent any damage. ❸ Please contact us if your requested working temperature lower than -20 °C ;