

ESS501I/V/IIC Ceramic Pressure Sensor Module (Electronics on PCB)

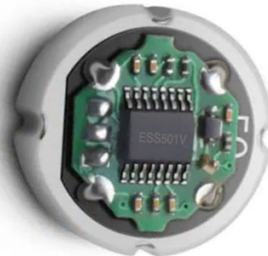

ESS501-I
Output: 4-20mA



ESS501-V
Output: 0.5-4.5V

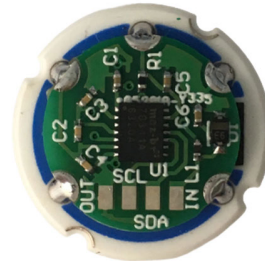

ESS501-IIC
Output: I2C

▪ Range: 0~2bar~600bar ▪ Diaphragm Material: Ceramic Al₂O₃ 96% ▪ Integrated accuracy: 0.5% ▪ Output: 0.5-4.5Vdc | 4-20mA | I2C

Description

Based on ESS501 Monolithic Ceramic Sensing call, ESS501I/V/IIC pressure sensors module is integrated with pcb which amplify the output from mv to analogy signal such as 0.5-4.5Vdc or 4-20mA and I2C.

Because of the Al₂O₃ ceramic excellent chemical resistance (aggressive gases, most of solvents and acids, etc.), no additional protection is normally required.

Key Features & Benefits

- Pressure range 0~2bar...50bar...600bar
- Excellent resistance to corrosion and abrasion
- Absolute measurement available
- Thermally compensated
- Extended customization

Application

- Cooling equipment & A/C system
- Automotive and vehicle
- Industrial process control
- HVAC system
- Refrigeration equipment
- Air conditioning unit

Technical Characteristics [for sensor module]

Parameter	Unit	Description			
Sensor type	-	Absolute (A), Gauge (R) or Sealed gauge (S)			
Technology	-	Piezoresistive			
Diaphragm material	-	Ceramic Al ₂ O ₃ 96% (standard), 99.6% or sapphire (Sapphire is underway)			
Weight	g	≤ 8 (ceramic cell only) ; ≤ 30 (module)			
Response time	ms	≤ 1 (@90%/FS)			
Output signal		0-5V	I2C	0.5-4.5V	4-20mA
Supply voltage	VDC	2...36	2.7-5.5	3.0-5.5	11-36
Current cons.	mA	≤ 3 @ 10V	2.5(TYP)	2.5(TYP)	-
Impedance	Ω	11k ± 30%	>10k	>10k	≤50 (U-11)
Offset	mv/v	- 0.2 ± 0.1 (Other nominal values available on request)			
Operating temperature	°C	-40...+85°C (-40 °F...+185 °F)			

Storage temperature		°C	-40...+125 °C (-40 °F...+257 °F)											
Nominal pressure FSO	bar	0.5	1	2	5	10	20	50	100	200	400	600	800	
	psi	7	14	29	73	145	290	725	1450	2900	5800	8700	11600	
Overload pressure	bar	1	2	4	10	15	35	100	150	350	500	750	1000	
	psi	14	29	58	145	217	507	1450	2175	5075	7250	10875	14500	
Burst pressure	bar	2	3	6	15	25	65	120	200	500	650	950	1250	
	psi	29	43	87	217	362	942	1740	2900	7250	9425	13775	18125	
Vacuum capability	bar	-0.1	-0.5	-1	-1	-1	-1	-1	-1	-1	-1	-1	-1	
	psi	-1.4	-7	-14	-14	-14	-14	-14	-14	-14	-14	-14	-14	
Type	-	R	A/R/S	A/R/S	A/R/S	A/R/S	A/R/S	A/R/S	S	S	S	S	S	
Total thickness	mm	6.15	6.17	6.23	6.30	6.35	6.55	6.70	6.70	7.05	7.32	7.55	8.05	
	in	0.242	0.2432	0.245	0.248	0.250	0.258	0.263	0.263	0.278	0.288	0.297	0.317	
Sensitivity	mv/v	1.4-	2.0-3.6	2.3-3.5	2.3-4.0	3.1-5.5	2.4-4.0	4.0-6.0	3.0-4.8	2.5-3.9	3.1-4.8	3.1-4.8	2.0-3.5	
Accuracy	%/fs	0.4/0.	0.3/0.9	0.3/0.6	0.2/0.4	0.2/0.5	0.2/0.5	0.2/0.5	0.2/0.5	0.4/0.9	0.5/1.0	0.5/1.0	0.5/1.0	
Thermal offset shift(typ./max.)	%/fs/k	± 0.005 / ± 0.040					25 °C...85 °C			(77 °F...185 °F)				
Thermal span shift	%/fs/k	≤ ± 0.010		≤ ± 0.012		≤ ± 0.014		0 °C...70 °C			(32 °F...158 °F)			
								-25 °C...0 °C / 70 °C...85 °C			(-13 °F...32 °F / 158 °F...185 °F)			
								-40 °C...-25 °C / 85 °C...135 °C			(-40 °F...-13 °F / 185 °F...275 °F)			
Reliability tests	-	1000 hours @85 °C (185 °F) & 85 %RH						500 thermal shocks -40°C...+150 °C (-40 °F... +302 °F)						
		1000 hours burn-in @150 °C (302 °F)						10 million 0 bar to Pnom pressure cycles						

Tests performed at 25°C in Eastsensor housings, unless otherwise specified. Different housings may affect performances.

1. Psi values for reference only.

2. The sensitivity of each production batch is constant, within the indicated range and with minimal dispersion.

3. Accuracy = $\sqrt{\text{NonLinearity}^2 + \text{Hysteresis}^2 + \text{NonRepeatability}^2}$, terminal based.

4. All technical characteristics will remain within indicated ranges performing the above-mentioned reliability tests.

5. Please consult manufacturer when pressure range with "*" *

Drawing

ESS501-V Ceramic Piezo-resistive Pressure Sensor module Range: 0bar-50bar, Output: 0.5-4.5V Power Supply: 5V

Top View (without supporter) | Schematics

Electronics on PCB

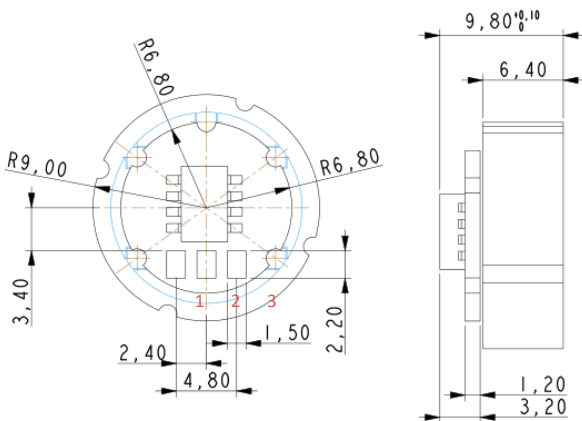

1	2	3
Power supply	Output	Power supply
"+"	Voltage	"-"

ESS501-I Ceramic Piezo-resistive Pressure Sensor module Range: 0bar~50bar, Output: 4-20mA Power Supply: 10-36V

Top View (without supporter) | Schematics

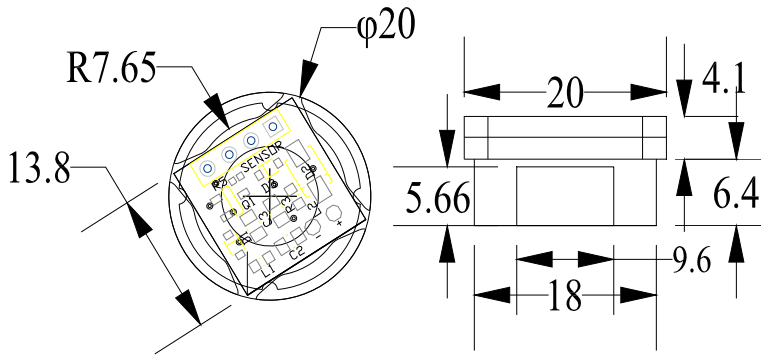

Electronics on PCB

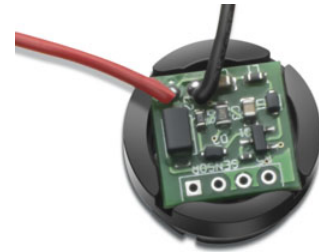

Red Wire	Black Wire
Power Supply “+”	Power Supply “-”

ESS501-IIC Ceramic Piezo-resistive Pressure Sensor module Range: 0bar~50bar, Output: I2C, Power Supply: 2.7-5.5V

Top View (without supporter) | Schematics

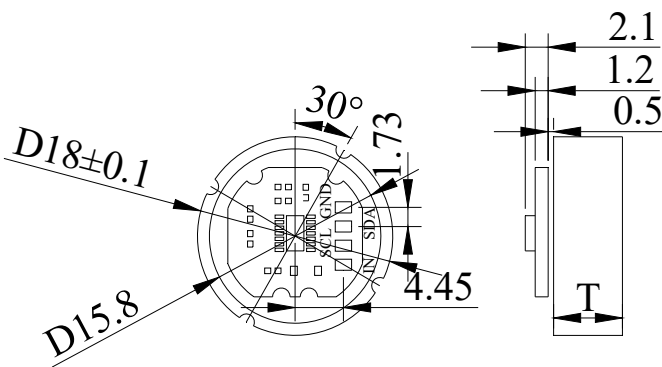

Electronics on PCB

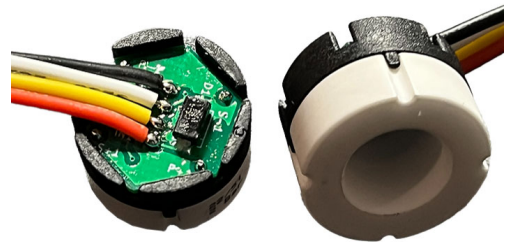

Output Signal	IIC
IN+	VCC
GND	GND
SCL	SCL
SDA	SDA

Range(bar)	1	2	5	10	20	50	SCL	SCL
T(mm)	6.17	6.23	6.30	6.35	6.55	6.7	SDA	SDA

Module Dimension with Black Ring Supporter For voltage output type when **pressure range ≤5bar** & Current output type

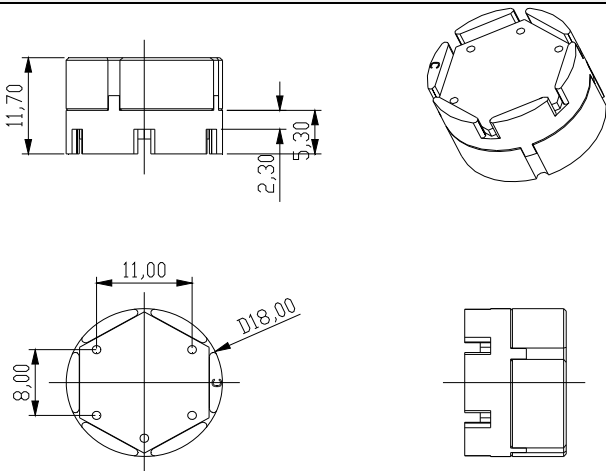

ESS501V: 0.5-4.5V | 0-5V ESS501I: 4-20mA



Wires connection for both current & voltage		
Red Wire	Voltage	Current module
	Positive	Power Supply “+”
Black Wire	Negative	Power Supply “-”
White Cable	Signal output SIG	NC

Ordering Procedure

ESS5		Ceramic Piezoresistive Pressure Sensor	
Code	Model		
01	Pressure Sensor Cell, Monolithic 18*6.35mm		
01 Thin	Pressure Sensor Cell, Monolithic 18*3.35mm		
01-I	Pressure Sensor Module, Monolithic (with pcb) 4-20mA; Electronics on PCB		
01-V	Pressure Sensor Module, Monolithic (with pcb) 0.5-4.5V; Electronics on PCB		
01-IIC	Pressure Sensor Module, Monolithic (with pcb) I2C Output; Electronics on PCB		
02 (18)	Pressure Sensor Cell, Flush diaphragm 18*6.35mm		
02	Pressure Sensor Cell, Flush diaphragm 18*3.35mm		
02 (12)	Pressure Sensor Cell, Flush diaphragm 12*12*3mm		
02 (14)	Pressure Sensor Cell, Flush diaphragm 14*14*3mm		
02 (21)	Pressure Sensor Cell, Flush diaphragm 21*4.35mm		
02-I	Pressure Sensor Module, Flush diaphragm (with pcb) 4-20mA; Electronics on PCB		
02-IOC	Pressure Sensor Module, Flush diaphragm (with pcb) 4-20mA; Electronics on Ceramic		
02-V	Pressure Sensor Module, Flush diaphragm (with pcb) 0.5-4.5V; Electronics on PCB		
02-VOC	Pressure Sensor Module, Flush diaphragm (with pcb) 0.5-4.5V; Electronics on Ceramic		
02-IIC	Pressure Sensor Module, Flush diaphragm (with pcb) I2C Output; Electronics on PCB		
02-IICOC	Pressure Sensor Module, Flush diaphragm (with pcb) I2C Output; Electronics on Ceramic		
03	Pressure Sensor Cell (with temperature sensor mounted), Monolithic 18*6.35mm		
03 Thin	Pressure Sensor Cell (with temperature sensor mounted), Monolithic 18*3.35mm		
Code	Span	Code	Span
R01	0...0.5 bar [0...7psi]	R07	0...50 bar [0...720psi]
R02	0...1 bar [0...14psi]	R08	0...100 bar [0...1450psi]
R03	0...2 bar [0...29psi]	R09	0...200 bar [0...2900psi]
R04	0...5 bar [0...72psi]	R10	0...400 bar [0...5800psi]
R05	0...10 bar [0...145psi]	R11	0...600 bar [0...8700psi]
R06	0...20 bar [0...290psi]	R12	0...800 bar [0...11600psi]
Code	Pressure Type		
R	Gauge		
A	Absolute		
S	Sealed Gauge		
Code			
M	Monolithic		
F	Flush Diaphragm		
Code	Sensitivity adjustment		
0	Without		
9	On request		
Code	Output		
0	0.5-4.5Vdc		
9	4-20mA		
10	IIC		
11	SENT		
12	SPI		
Code	Termination type		
02	Pre-tinned pads		
03	Silicone single wires 80 mm-100 mm		
Code	Accuracy		
1	0.5%		
2	1.0%		
9	Others on request		

Note: ❶ Extremely attention must be paid to sensor installation process to avoid any miss conduction that affect the sensor performance, ❷ please protect the diaphragm and the compensated board carefully to prevent any damage. ❸ Please contact us if your requested working temperature lower than -20 °C