

ESS501 Ceramic Piezo-Resistive Pressure Sensor Cell

MONOLITHIC THICK-FILM | Al₂O₃ 96%



18mm * 6.35mm

18mm * 3.5mm

- Range: 0~480bar/680bar
- Size: 18mm*6.35mm; 18mm*3.5mm
- Diaphragm Material: Ceramic Al₂O₃ 96%
- Power Supply: 2-30V
- Long Term Stability: 0.3%/FS
- Temperature Compensation: -10...70°C
- Working Temperature: -40...+135 °C

Description

ESS501 **Monolithic Pressure Sensor Cell** are made with a **Ceramic Base Plate and Diaphragm** and work following the piezoresistive principle. The Wheatstone bridge is **Screen Printed** on one side of the flush ceramic diaphragm which is, in turn, glued to the sensor's body. The bridge faces the inside where a cavity is made and the diaphragm's opposite side can therefore be exposed directly to the medium to be measured.

The Wheatstone bridge is screen printed directly on one side of the ceramic diaphragm by means of **Thick Film Technology**. Because of the **Al₂O₃ Ceramic** excellent chemical resistance (**aggressive gases, most of solvents and acids**, etc.), no additional protection is normally required. Thanks to the reinforced outer area (monolithic structure), the sensor can be mounted directly in a plastic or metallic case by using O-ring.

ESS501 **Monolithic Pressure Sensor Cell** are available with two kind size: **18*6.35mm and 18*3.5mm (thin type)**, both are thermally compensated by laser-adjustable PTC resistors and the use of ceramic ensures a high linearity across the entire range of measurement, reducing effects of hysteresis to a minimum.

Key Features & Benefits

- Pressure range 0-2bar-480bar/680bar
- Excellent resistance to corrosion and abrasion
- Absolute measurement available
- Thermally compensated
- Extended customization
- Extended choice of measuring ranges

Application

- Cooling equipment & A/C system
- Automotive and vehicle
- Industrial process control
- HVAC system
- Refrigeration equipment
- Air conditioning unit

Technical Characteristics

Parameter	Unit	Description
Sensor type	-	Flush diaphragm, absolute (A), gauge (R) or sealed gauge (S)
Technology	-	Piezoresistive (Ceramic Thick Film)
Diaphragm material	-	Ceramic Al ₂ O ₃ 96% (standard), 99.6% or sapphire (on request)
Weight	g	≤ 8 (ceramic cell only)
Response time	ms	≤ 1
Supply voltage	VDC	2...30

Offset	mv/v	- 0.1 ± 0.1 (Other nominal values available on request)											
Current cons.	mA	≤ 1.3 @ 10V											
Operating temperature	°C	-40...+135 (-40 °F...+275 °F)											
Storage temperature	°C	-40...+150 (-40 °F...+302 °F)											
Impedance	kΩ	11 ± 30%											
Nominal pressure FSO	bar	0.5*	1*	2	5	10	20	50	100	200 *	400 *	600 *	800 *
	psi	7	14	29	73	145	290	725	1450	2900	5800	8700	11600
Overload pressure	bar	1	2	4	10	15	35	100	150	350	500	750	1000
	psi	14	29	58	145	217	507	1450	2175	5075	7250	10875	14500
Burst pressure	bar	2	3	6	15	25	65	120	200	500	650	950	1250
	psi	29	43	87	217	362	942	1740	2900	7250	9425	13775	18125
Vacuum capability	bar	-0.1	-0.5	-0.5	-1	-1	-1	-1	-1	-1	-1	-1	-1
	psi	-1.4	-7	-7	-14	-14	-14	-14	-14	-14	-14	-14	-14
Type	-	R	A/R/S	A/R/S	A/R/S	A/R/S	A/R/S	A/R/S	S	S	S	S	S
Total thickness	mm/in	6.40 ± 0.05/2.51 ± 0.2											
	mm/in	3.55 ± 0.05/1.40 ± 0.2; for thin type											
Sensitivity	mv/v	1.4-	2.0-3.6	2.3-3.5	2.3-4.0	3.1-5.5	2.4-4.0	4.0-6.0	3.0-4.8	2.5-3.9	3.1-4.8	3.1-4.8	2.0-3.5
Accuracy	%/fs	0.4/0	0.3/0.9	0.3/0.6	0.2/0.4	0.2/0.5	0.2/0.5	0.2/0.5	0.2/0.5	0.4/0.9	0.5/1.0	0.5/1.0	0.5/1.0
Thermal offset shift (typ./max.)	%/fs/k	± 0.005 / ± 0.040			25 °C...85 °C				(77 °F...185 °F)				
Thermal span shift	%/fs/k	≤ ± 0.010 ≤ ± 0.012 ≤ ± 0.014			0 °C...70 °C -25 °C...0 °C / 70 °C...85 °C -40 °C...-25 °C / 85 °C...135 °C				(32 °F...158 °F) (-13 °F...32 °F / 158 °F...185 °F) (-40 °F...-13 °F / 185 °F...275 °F)				
Reliability tests	-	1000 hours @85 °C (185 °F) & 85 %RH 1000 hours burn-in @150 °C (302 °F)						500 thermal shocks -40°C...+150 °C (-40 °F... +302 °F) 2-5 million 0 bar to Pnom pressure cycles					

Tests performed at 25°C in Eastsensor housings, unless otherwise specified. Different housings may affect performances.

1. Psi values for reference only.
2. The sensitivity of each production batch is constant, within the indicated range and with minimal dispersion.
3. Accuracy = $\sqrt{\text{NonLinearity}^2 + \text{Hysteresis}^2 + \text{NonRepeatability}^2}$, terminal based.
4. All technical characteristics will remain within indicated ranges performing the above-mentioned reliability tests.
5. Please consult manufacturer when pressure range with "*" *



Drawing

ESS501 Ceramic Piezo-resistive Pressure Sensor Range: 0bar~600bar

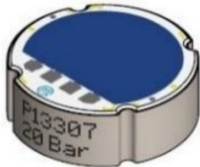
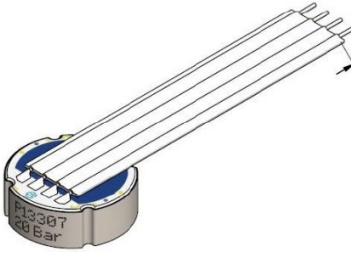
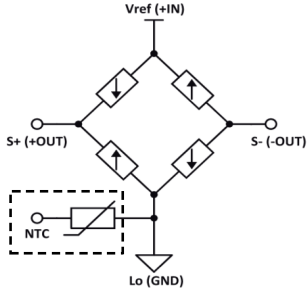
Top View: Pitch 2.54mm (0.100 inches)	Side View	Bottom View								
<table border="1"> <tr> <td>Vs</td> <td>Voltage Supply</td> </tr> <tr> <td>Gnd</td> <td>Ground</td> </tr> <tr> <td>S+</td> <td>Signal positive</td> </tr> <tr> <td>S-</td> <td>Signal negative</td> </tr> </table>	Vs	Voltage Supply	Gnd	Ground	S+	Signal positive	S-	Signal negative		
Vs	Voltage Supply									
Gnd	Ground									
S+	Signal positive									
S-	Signal negative									

<p>Type A: Pre-tinned soldering pads</p> 	<p>Pitch: 2.54 ± 0.05 Op. Temp: -40°C...+135°C Type A; -40°C...+105°C Type B Cable length: 80.8 ± 2</p>	<p>Type B: Polyester/Silicone cable</p> 	<p>Schematics</p> 
---	---	---	---

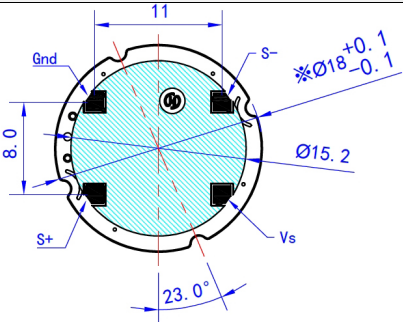
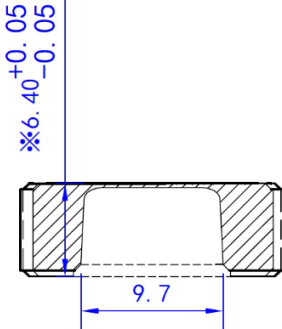
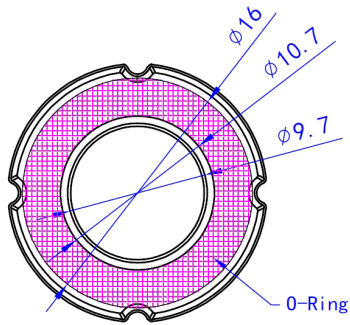
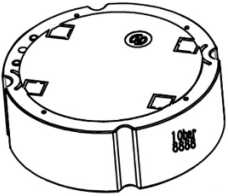
ESS501 Ceramic Piezo-resistive Pressure Sensor Range: 0bar~600bar; Pins layout at two lines

<p>Top View: Pitch 11mm (0.433 inches)</p>  <table border="1" data-bbox="140 1115 549 1211"> <tr> <td>Vs</td> <td>Voltage Supply</td> </tr> <tr> <td>Gnd</td> <td>Ground</td> </tr> <tr> <td>S+</td> <td>Signal positive</td> </tr> <tr> <td>S-</td> <td>Signal negative</td> </tr> </table>	Vs	Voltage Supply	Gnd	Ground	S+	Signal positive	S-	Signal negative	<p>Side View</p> 	<p>Bottom View</p> 
Vs	Voltage Supply									
Gnd	Ground									
S+	Signal positive									
S-	Signal negative									
										

ESS501[Thin Type] Ceramic Piezo-resistive Pressure Sensor Range: 0bar~100bar

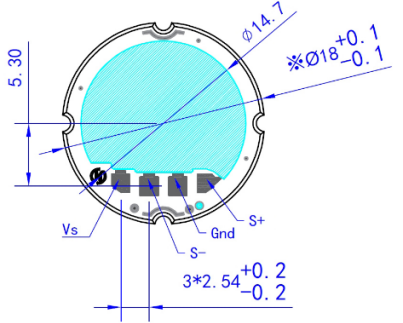
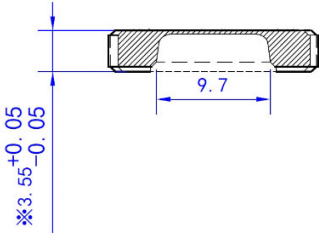
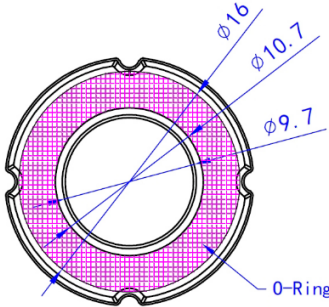
<p>Top View: Pitch 2.54mm (0.100 inches)</p> 	<p>Side View</p> 	<p>Bottom View</p> 
--	--	--

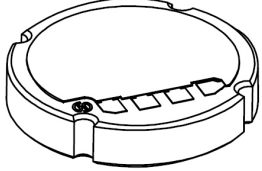
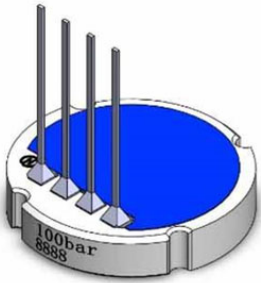
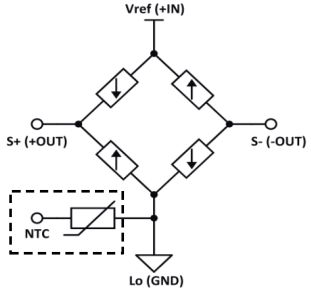
<p>Type A: Pre-tinned soldering pads</p> 	<p>Pitch: 2.54 ± 0.05 Op. Temp: -40°C...+135°C Type A: -40°C...+105°C Type B Pin section: 0.51 x 0.25 Pin length: L = 9.0 ± 0.5</p>	<p>Type B: 4 Pitch: 2.54 ± 0.05;</p> 	<p>Schematics</p> 
---	---	--	---

- Storage Conditions:** Store at 10~35°C with ≤70% RH. Avoid places that are too hot, exposed to direct sunlight, dusty, or have corrosive gases. The metal pins can easily oxidize in the air, so it's recommended to use the product within 10 days after unpacking. Under proper storage conditions, the soldering validity is 12 months. If stored for more than 12 months, the ceramic core needs to be rechecked for solderability and can only be used if it passes inspection.
- Product Installation Pressure:** During crimping installation, the crimping pressure should not exceed 20KN, and the direct pressure on the core should not exceed 5KN. Excessive force may damage the core structure or cause abnormal output signals. The ceramic core should not come into direct contact with hard objects like a metal casing to avoid significant internal stress and unstable output.
- Sealing Recommendations:** When using sealing rings, ensure that the sealing ring is centered with the elastic diaphragm and without uneven force. The inner diameter of the sealing ring should be >11.0mm and the outer diameter <16.0mm after compression deformation.
- Solder Pads:** The solder pads are made of Pd/Ag, with dimensions of 1.6*1.6mm. Recommended soldering method: Place the ceramic core on a constant-temperature soldering station at 100-120°C. When soldering with a soldering iron, keep the temperature ≤330°C. Each soldering time should be less than 3 seconds and should not exceed 2 times.

Ordering Procedure

ESS5	Ceramic Piezoresistive Pressure Sensor			
Code	Model			
01	Pressure Sensor Cell, Monolithic 18*6.35mm; 4 pins inline			
01 2-lines	Pressure Sensor Cell, Monolithic 18*6.35mm; 4 pins at two sides			
01 Thin	Pressure Sensor Cell, Monolithic 18*3.35mm; 4 pins inline			
01-I	Pressure Sensor Module, Monolithic (with pcb) 4-20mA; Electronics on PCB			
01-V	Pressure Sensor Module, Monolithic (with pcb) 0.5-4.5V; Electronics on PCB			
01-IIC	Pressure Sensor Module, Monolithic (with pcb) I2C Output; Electronics on PCB			
02 (18)	Pressure Sensor Cell, Flush diaphragm 18*6.35mm			
02 (18)Thin	Pressure Sensor Cell, Flush diaphragm 18*3.35mm			
02 (12)	Pressure Sensor Cell, Flush diaphragm 12*12*3mm			
02 (14)	Pressure Sensor Cell, Flush diaphragm 14*14*3mm			
02 (21)	Pressure Sensor Cell, Flush diaphragm 21*4.35mm			
02-I	Pressure Sensor Module, Flush diaphragm (with pcb) 4-20mA; Electronics on PCB			
02-IOC	Pressure Sensor Module, Flush diaphragm (with pcb) 4-20mA; Electronics on Ceramic			
02-V	Pressure Sensor Module, Flush diaphragm (with pcb) 0.5-4.5V; Electronics on PCB			
02-VOC	Pressure Sensor Module, Flush diaphragm (with pcb) 0.5-4.5V; Electronics on Ceramic			
02-IIC	Pressure Sensor Module, Flush diaphragm (with pcb) I2C Output; Electronics on PCB			
02-IICOC	Pressure Sensor Module, Flush diaphragm (with pcb) I2C Output; Electronics on Ceramic			
03	Pressure Sensor Cell (with temperature sensor mounted), Monolithic 18*6.35mm			
03 Thin	Pressure Sensor Cell (with temperature sensor mounted), Monolithic 18*3.35mm			
	Code	Span	Code	Span
	R01	0...0.5 bar [0...7psi]	R07	0...50 bar [0...720psi]
	R02	0...1 bar [0...14psi]	R08	0...100 bar [0...1450psi]
	R03	0...2 bar [0...29psi]	R09	0...200 bar [0...2900psi]
	R04	0...5 bar [0...72psi]	R10	0...400 bar [0...5800psi]
	R05	0...10 bar [0...145psi]	R11	0...600 bar [0...8700psi]
	R06	0...20 bar [0...290psi]	R12	0...800 bar [0...11600psi]

				Code	Pressure Type	
				R	Gauge	
				A	Absolute	
				S	Sealed Gauge	
				Code	Sensitivity adjustment	
				0	Without	
				9	On request	
				Code	Thermal offset	
				0	≤ ± 0.06 % FS/K (not thermally compensated)	
				1	≤ ± 0.04 % FS/K	
				2	≤ ± 0.02 % FS/K	
				Code	Termination type	
				02	4 pins, Pre-tinned pads, pitch 2.54 mm	
				03	4 pins, Silicone single wires 80 mm, pitch 2.54 mm	
				04	4-pin, in-line H=9.0± 0.5 mm, pitch 2.54 mm	
				Code	Additional coating	
				1	Without	
				2	Parylene coating	
ESS5	01	R10	R	0	2	03 1

Note: ① Extremely attention must be paid to sensor installation process to avoid any miss conduction that affect the sensor performance, ② please protect the diaphragm and the compensated board carefully to prevent any damage. ③ Please contact us if your requested working temperature lower than -20 °C ;