

ESS323 Welded Flush Diaphragm (Joint Type) Pressure Sensor

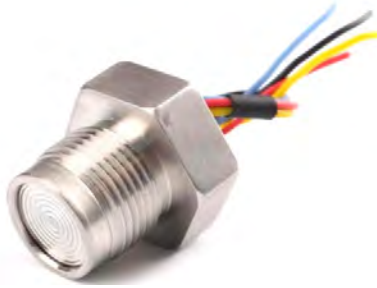

Range: -100Kpa~10MPa Overload Pressure: 150%~300% Accuracy: 0.2%/FS Φ19mm Welded Flush Diaphragm

Description

ESS323 Welded Diaphragm Pressure Sensor, with narrow range and joint type connection, is the simplified version of ESS322, it uses a high-sensitivity piezoresistive silicon die as sensing component, which is protected against ambient influences by SS316 housing sealed with a concentrically corrugated diaphragm. Inside the housing, the filled silicone oil assures the measured pressure can be transmitted onto silicon die and then transform the pressure to electric signal.

ESS323 is available pressure ranges from -100Kpa to 10MPa.

Key Features & Benefits

- Pressure range -100Kpa~10MPa
- Gauge, Absolute, Sealed gauge
- Constant current/Voltage power supply
- Isolated construction, measure various media
- Φ19mm OEM Pressure Sensor
- Full Stainless Steel 316
- Wide temperature compensation -10°C~80°C
- Long-term stability ±0.2%FS/year

Application

- Industrial process control
- Level measurement
- Gas, liquid pressure measurement
- Pressure checking meter
- Pressure calibrator
- Liquid pressure system and switch
- Cooling equipment & A/C system
- Aviation and navigation inspection
- Pneumatics and hydraulics systems

Standard Range

Range	Overload	Output/F.S (mV)	Typical Value(mV)	Pressure Type
0~10KPa	300%	35~60	45	G
0~20KPa	300%	70~110	90	G/A
0~35KPa	300%	55~80	70	G/A/D
0~70KPa	300%	55~80	60	G/A/D
0~100KPa	300%	60~85	75	G/A/D
0~200KPa	300%	60~85	75	G/A/D
0~400KPa	300%	60~80	70	G/A/D

Technical Parameters

Parameters	Typ.	Max.	Unit
Nonlinearity	0.2	0.5	%FS
Hysteresis	0.05	0.1	%FS
Repeatability	0.05	0.1	%FS
Zero Output	±1	±2	mV DC
FS Output	100		mV DC
Input/ Output Impedance	2.6	3.8	kΩ
Zero Temp. Drift*	±0.15	±0.8	%FS,@25°C

ESS323 GID-3-EV03.0

0~600KPa	200%	90~120	100	G/A/D
0~1.0 MPa	200%	125~185	150	G/A/D
0~1.6 MPa	200%	80~120	100	G/A/D
0~2.0 MPa	200%	50~70	60	G/A/D
0~3.5 MPa	200%	100~120	110	G/A/D
0~7.0 MPa	200%	120~150	135	G/A
0~10 MPa	200%	180~230	200	G/A
0~25 MPa	150%	140~170	150	S
0~40 MPa	150%	230~280	250	S
0~60 MPa	150%	100~160	130	S
0~100 MPa	150%	100~150	120	S

Notes: G for Gauge pressure; A for Absolute pressure; D for Differential pressure; S for Sealed gauge.

Sensitivity Temp. Drift*	±0.2	±0.7	%FS,@25°C
Long-term Stability	0.1		%FS/year

Range -100kPa~100MPa

*The typical value of 0~10kPa and 0~20kPa's zero temperature drift and sensitivity temperature drift is 0.4%FS@25°C, max value is 1.6%FS@25°C



Construction Performance

Diaphragm: Stainless Steel 316L
Housing: Stainless Steel 316L
Pressure leading tube: Stainless Steel 316L
O Ring: Φ16*1.8mm (nitrile rubber or viton)
Measuring Medium: Which is compatible with SS316L, viton, nitrile rubber
Packing Medium: Silicon Oil
Net weight: 50~80g

Electric & Environment Performance

Power supply: 1.5mA/5V (Max input voltage is 10VDC)
Insulation Resistance: 500MΩ@500VDC
Overpressure: 1.5~3 times FS
Vibration (20~500Hz): 20G
Useful Time (25°C): >1*100 Million Times @Pressure Circulation(80%FS)
Response Time: ≤1ms
Storage Temp.: -40~+125°C
Operating Temp.: -40~+85°C
Compensation Temp.: 0~50°C; -10~80°C @ 0~70 (7kPa,20 kPa,35 kPa)

Drawing

ESS323 Welded Diaphragm Pressure Sensor Range:-100Kpa~10Mpa

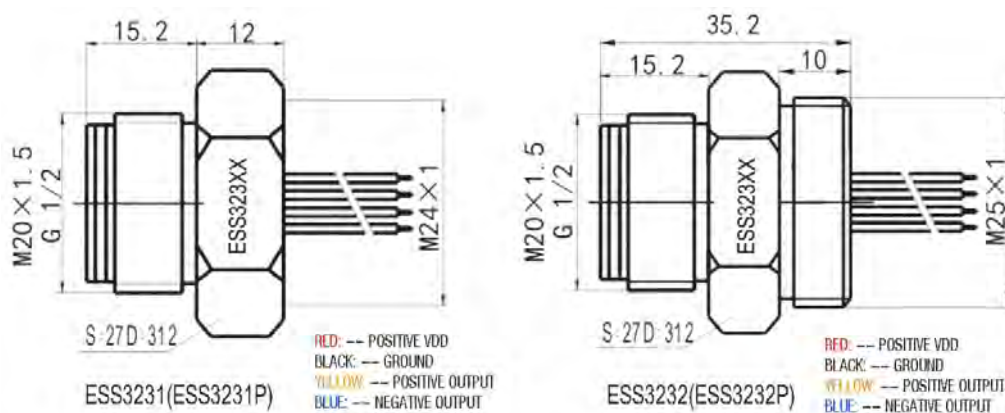

Ordering Procedure

ESS3	Welded Diaphragm Pressure Sensor						
	Code	Model					
	23	Welded Joint Type Pressure Sensor					
	23P	Welded Flush Diaphragm Pressure Sensor					
		Cod	Span	Code	Span	Code	Span
		R01	0~10KPa	R07	0~400KPa	R13	0~7.0 MPa
		R02	0~20KPa	R08	0~600KPa	R14	0~10 MPa
		R03	0~35KPa	R09	0~1.0 MPa		
		R04	0~70KPa	R10	0~1.6 MPa		
		R05	0~100KPa	R11	0~2.0 MPa		
		R06	0~200KPa	R12	0~3.5 MPa		
		Code	Pressure Type				
		G	Gauge				
		A	Absolute				
		S	Sealed Gauge				
		Code	Power Supply				
		M	1.5mA				
		V5	5V				
		V10	10V				
		Code	Process Connection				
		P1	M20*1.5				
		P4	G1/2				
		P5	G1				
		Code	Pressure connection				
		0	O-ring -NBR				
		1	O-ring -Viton				
		Code	Electric connection				
		1	Kovar pin				
		2	Rubber flexible silicon wires (10cm)				
ESS3	23	R10	G	M	P1	1	1

Note: ❶ Extremely attention must be paid to sensor installation process to avoid any miss conduction that affect the sensor performance, ❷ please protect the diaphragm and the compensated board carefully to prevent any damage. ❸ Please contact us if your requested working temperature lower than -20 °C